

VILLAVERDE

LONDON

MANHATTAN

MURANO BAR CHANDELIER I 0437

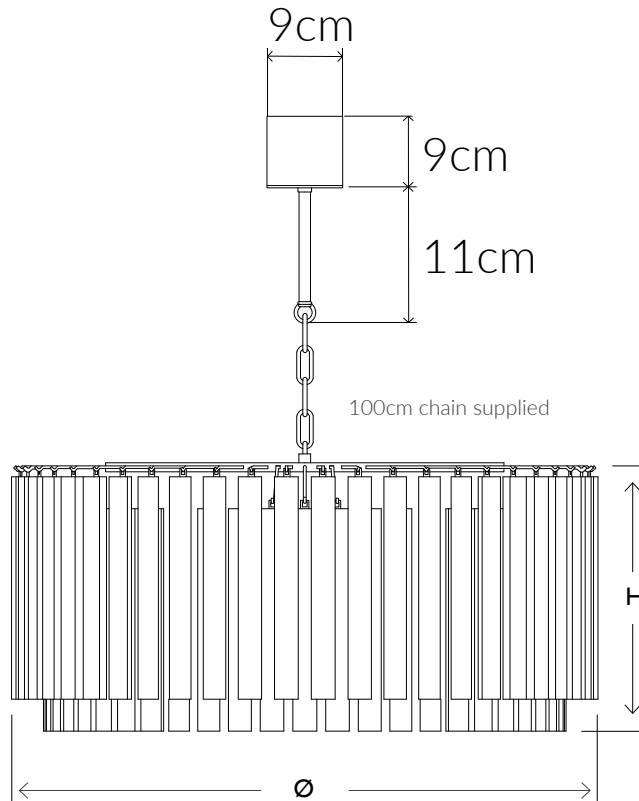

Consult chart (right) for sizing

*The product height, does not include the ceiling cup dimension.
Please refer to the diagram above for the ceiling cup dimensions.

All products are handmade, therefore variances may occur.



SIZES*

3 light (E14)	H 33cm H 12.9"	Ø 25cm Ø 9.8"	Kg 16 Lb 35.2
3 light (E27)	H 33cm H 12.9"	Ø 35cm Ø 13.7"	Kg 21 Lb 46.2
4 light	H 33cm H 12.9"	Ø 45cm Ø 17.7"	Kg 34 Lb 74.9
6 light	H 33cm H 12.9"	Ø 60cm Ø 23.6"	Kg 40 Lb 88.18
8 light	H 33cm H 12.9"	Ø 75cm Ø 29.5"	Kg 60 Lb 132.2
9 light (small)	H 33cm H 12.9"	Ø 90cm Ø 35.4"	Kg 85 Lb 187.3
9 light (large)	H 33cm H 12.9"	Ø 100cm Ø 39.3"	Kg 100 Lb 220.4
12 light	H 33cm H 12.9"	Ø 120cm Ø 47.2"	Kg 120 Lb 264.5
18 light	H 33cm H 12.9"	Ø 130cm Ø 51.1"	Kg 130 Lb 286.6

MATERIALS

MURANO
Hand crafted murano

OTHER FINISHES
Frame available in Chrome
or Gold

MURANO COLOURS

Colour palettes available online

SUSPENSION

All ceiling lights are supplied with approximately 100cm or 40" of chain. If additional chain is required please specify. Additional costs may apply.

FIXING

Ensure the hook is suitable to carry the weight of the product and fitted before the chandelier installation.
Ceiling Hook not supplied.

INSTALLATION

Fixture requires on site assembly by a qualified electrician.

ELECTRICALS

Lightbulbs are not supplied - ADVISE LED bulb.

UK

220V E14 Candle bulb
40W max per bulb (Standard) - 6W LED per bulb

USA

120V E12 Candle bulb
40W max per bulb (Standard) - 6W LED per bulb

Or

UK

220V E27 Candle bulb
40W max per bulb (Standard) - 6W LED per bulb

USA

120V E26 Candle bulb
40W max per bulb (Standard) - 6W LED per bulb

USA Regulations may affect the Design.

STANDARD

All lighting is made to CE standards
UL listing upon request

SHADES

Shades are not available for this product.